

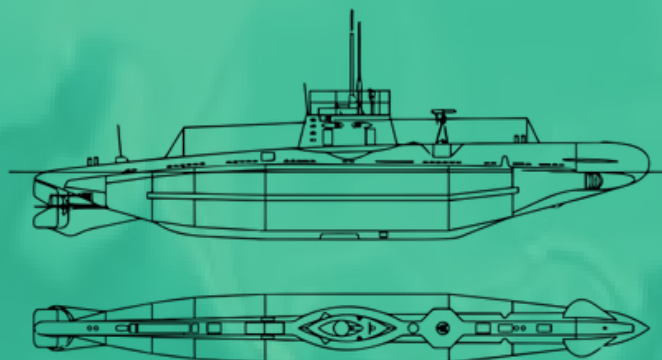

Sponsorship Package

UPR Mayagüez Campus
Autonomous Underwater Vehicle
2023-2024



Index

About Us.....	1
Proteus-AUV.....	2
Hydrus-AUV.....	3
RoboSub Competition.....	4
Sub-teams.....	5
Cost and Expenses.....	9
Benefits.....	10
Payment Methods.....	11
Sponsors.....	12
Contact Information.....	13



About Us

The University of Puerto Rico's Mayagüez Campus is where Team RUMarino was established in 2015 as part of College Robotics for Manufacturing Engineers (CROME). This is a student organization that helps engineering students use robotics and autonomous vehicles to put what they've learned in class into reality. The IEEE, of which RUMarino is currently a member, aims to aid students in exploring and learning about subjects not covered by the university's curriculum. Furthermore, our Team specializes in designing and innovating an Autonomous Underwater Vehicle (AUV) to compete in the annual RoboSub Competition. We are the first group of college students in the Caribbean to create an autonomous underwater vehicle (AUV) that is competing in the RoboSub competition. The team includes 30 members from various engineering branches such as: Mechanical, Industrial, Electrical and Computer Engineering. By working together as a team, our members are taught revolutionary technology that will prepare them technically and professionally for their future careers.

As part of our accomplishments in previous competitions, our team qualified for the quarterfinals and finished 21st out of 44 competitors in 2017, 17th out of 47 competitors in 2018, and 15th out of 59 participants in 2019, all while using very little funding. Additionally, the team won the Perseverance Award in 2017 and 2018 from Teledyne Marine, a tournament official sponsor for the second year in a row. Moreover, RUMarino received the 2017 Association for Unmanned Vehicle Systems International Best New Entry Award (AUVSI). The crew finally acquired Doppler Velocity Log (DVL) in 2020 as a result of a Teledyne Marine-sponsored competition.



Proteus - AUV

Proteus is RUMarino's first AUV. Proteus has four main sensors which are: cameras used to detect the obstacles in a course; a pressure sensor to control the vehicle's depth; an Attitude and Heading Reference System (AHRS) used to control the heading movement of the vehicle; and finally, three hydrophones for acoustic signal detection of the underwater location of the source. In the competition Proteus will have to complete different tasks and maneuver through obstacles. The tasks we face in the competition change every year. Proteus has successfully been tested autonomously and made quite a strong impression in its first appearance at the RoboSub 2017 competition, leading to awards in recognition of our performance. Currently we are developing a new design for our new AUV with improved mechanical and electrical structures and more robust software system.

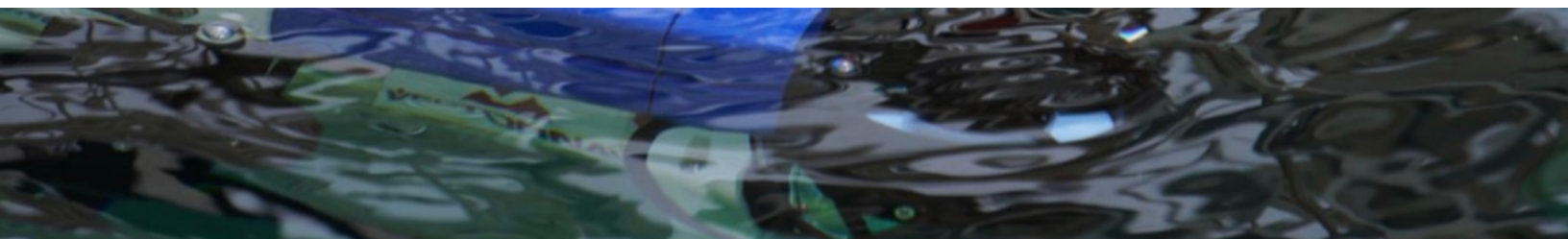



Hydrus - AUV

Hydrus is our newest Autonomous Underwater Vehicle designed with modularity and future expansion in mind. Measuring 3 feet long, carrying a stereoscopic camera, 8 thrusters, dual torpedo launchers, and a more extensive sensor suite, Hydrus is a complete leap forward in capability from its predecessor. It is the foundation for future improvements both in software and hardware and represents the cumulative progress that the team has achieved.



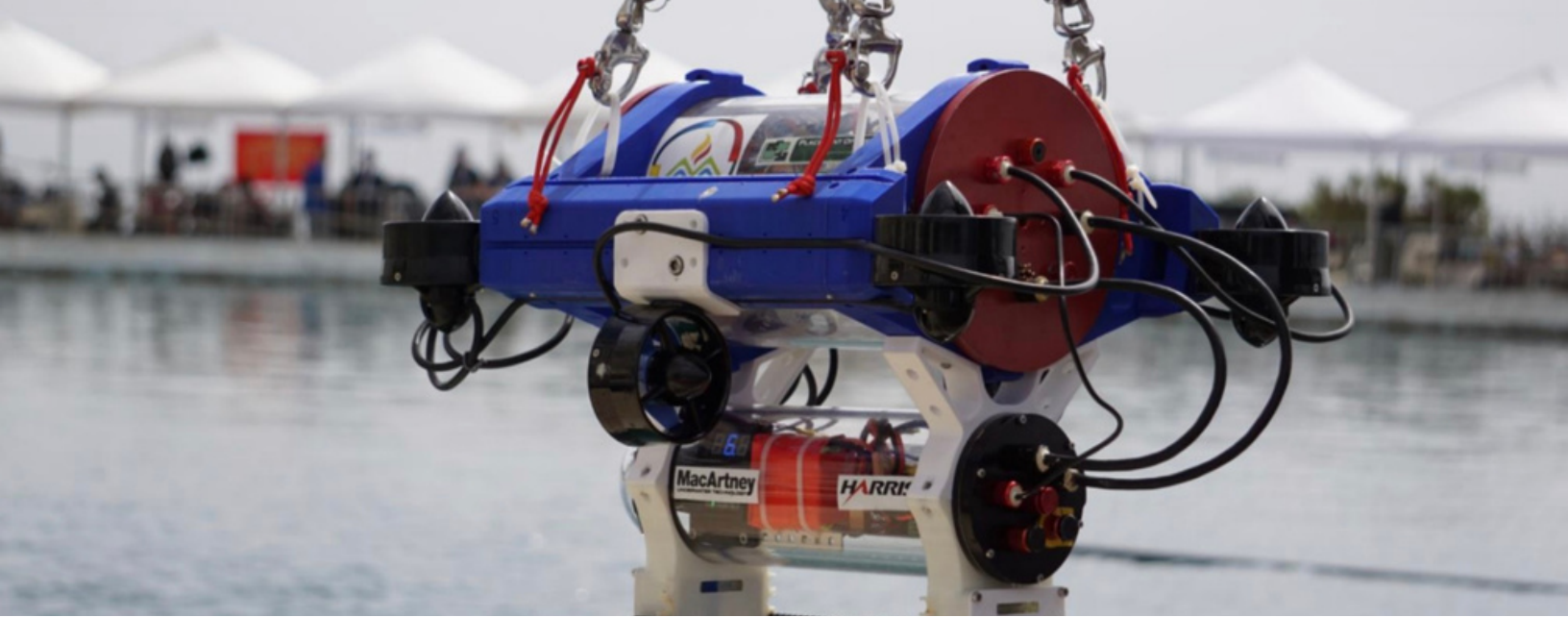

Robo-Sub Competition

Robo-Sub is an annual international competition where teams from all over the world gather at SSC Pacific's TRANSDEC facility in San Diego, California. While this event's main focus is finding the top AUV through a series of rigorous obstacle competitions, it also provides a platform for students to travel, network, and share ideas with others they'd normally not have a chance to. Students will put their AUV to the test by completing different missions. These range from precisely navigating through a gate, locating underwater signals, firing torpedoes, and many others. Once the missions begin, AUV's complete obstacles without any interaction from the participating students, and that's putting the "autonomous" in "autonomous underwater vehicle". The competition is co-sponsored by the Association for Unmanned Vehicle Systems International (AUVSI) and the U.S Office of Naval Research (ONR).



Sub-Teams

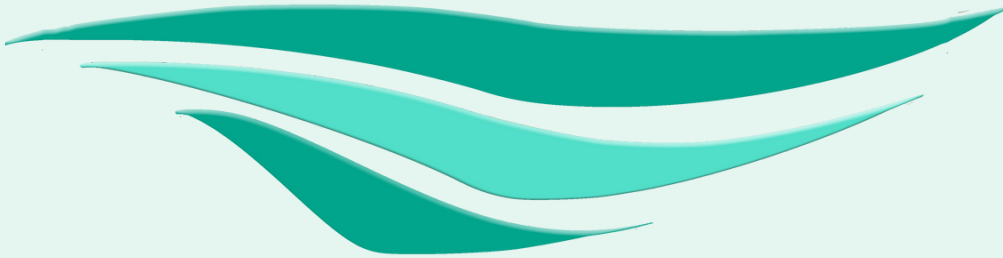

"Alone we can do so little; together we can do so much."

-Helen Keller

Computer System

- Software Architecture Division
- Control Systems Division
- Sonar Systems Division
- Computer Vision Division
- Embedded Systems Division

Mechanical

- Mechanical Structure Division
- Electrical Systems Division

Management

- Business Operations



Computer Systems

Software is the brain of the AUV. From vision to motors, these are the spinal cords that combine everything together. The software collects data from sensors, processes it, and makes meaningful decisions from them. This team is composed of Computer Vision, Software Architecture, Controls, Sonar and Embedded Systems.

The Software Development Division handles the development of all the software within the AUV. This includes the mission logic and the vehicle's interactions with the environment. Some of the logic implemented was the mission controller, that is, a sequential program that decides what mission the vehicle will complete at a certain moment. Also, in this division most of the sensors such as the Doppler Velocity Logger (DVL), Inertial Measurement Unit (IMU) and ZED Stereo Vision Camera are implemented and modified for the software. Low-level programming is also an important part of the team, as it works directly with the microcontrollers that make possible the movement of the vehicle. Currently, the team is designing and starting to implement a completely new approach to the tasks and obstacles of the 202 RoboSub competition.



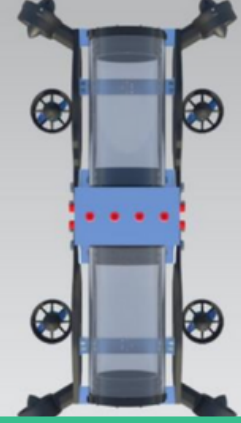
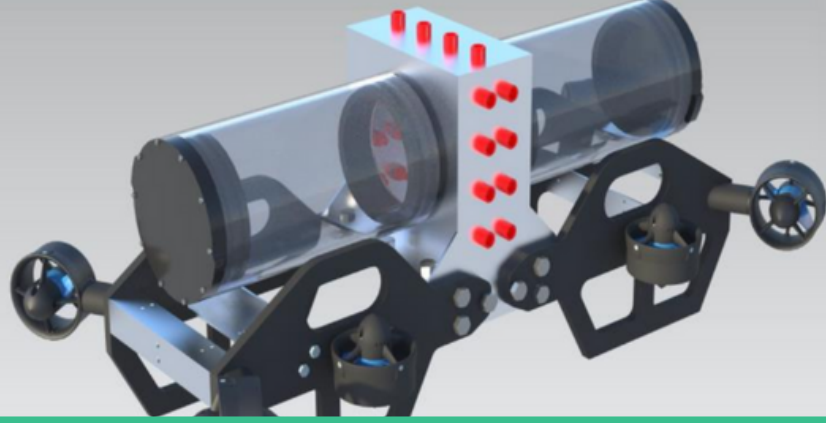

Hardware

The mechanical team are responsible for the mechanical integrity and functionality of the AUV. It ranges from the chassis to individual actuators such as thrusters, claws or torpedos. This division oversees the design of the whole vehicle in CAD software. It also does different analysis such as: Computer Fluids Dynamics (CFD) models, center of gravity calculations, and buoyancy calculations. The team also manufactures and builds the complete structure. This semester, the mechanical team has been completely redesigning the structure of our new AUV using Siemens NX and other designing programs.

On the other hand, the electrical team is responsible for the organization of the interior layout of the electrical components, the design and implementation of the power distribution boards, and the design of the control system. Components such as: kill switches, voltage regulators, microcontrollers, and many others are implemented by this team. The team also designed the Printed Circuit Boards (PCB) in Proteus. The Electrical Systems Division is currently designing the new racks inside the cabins. This new design will ensure a correct operation while fixing previous points of failure, making for a more robust design.

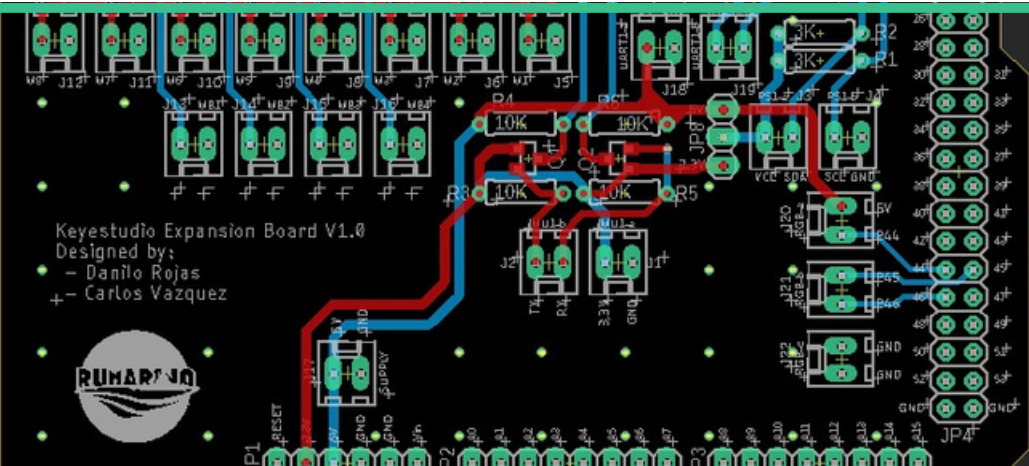



Management

A division created to optimize the whole structure of the team. Its purpose is to mature RUMarino as it grows memberships, complexity and ambition. This team leads communication with potential sponsors, and makes relations between companies and the team. Operations Management optimizes the leading experience and procedures of the 9 multidisciplinary teams that compose RUMarino addressing their infrastructural, technological, personnel, and intellectual needs. This team also develops and oversees progress reports and process documentation for the future generations of RUMarino members to facilitate the transfer of knowledge from members that are graduating to new members in training by developing Standard Operating Procedures. Also, along with the Business Management Division, it relieves administrative responsibilities from the team leads and members that focus on developing the AUV.

The business team manages the team resources such as revenue streams, documentation, and inventory which keeps the team operational and running efficiently. This team is also responsible of finding opportunities to promote Proteus, Hydrus and STEM fields for students in elementary, intermediate, and high school. This assure students to aspire to have further studies within these disciplines at the University of Puerto Rico, Mayagüez Campus. More information about the Team's Outreach activities can be found in our website: rumarino.org.



Cost and Expenses

Our general team's expenses are divided into AUV Materials and Travel Expenses, combined in a total of \$19,500. To help us cover our expenses, we encourage you to consider one of our four sponsorship tiers with exclusive benefits listed in the next page of this document.

General Team's Expenses

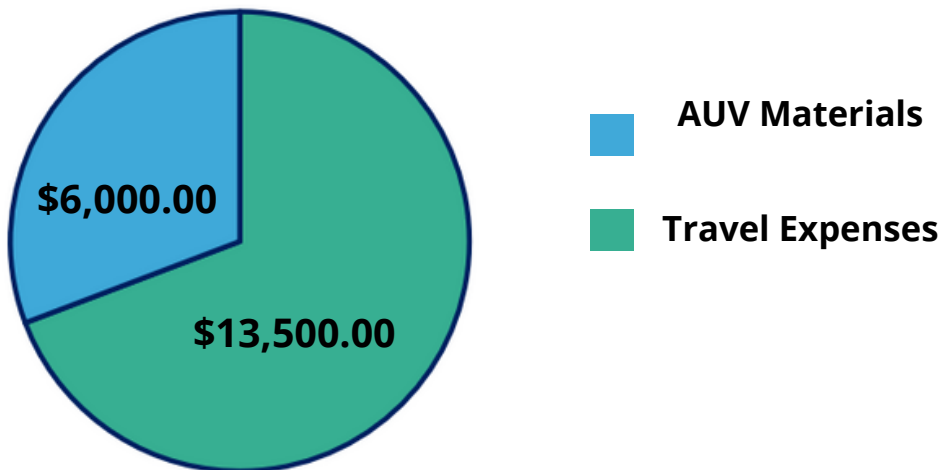

Benefits of your Sponsor

1. Support the development of students in Science, Technology, Engineering and Mathematics (STEM), and Business Administration areas.
2. Promote the cutting-edge field of autonomous vehicles in Puerto Rico. The UPRM is the first university of Puerto Rico and Caribbean to compete in RoboSub.
3. Network with talented students with experience, knowledge and innovative ideas. Sponsors have already chosen members of RUMarino for internships and full time jobs in companies such as: Lockheed Martin, Boeing, Honeywell, GM, etc. due to their knowledge obtained within this project.
4. Sponsoring a nonprofit student organization in the University of Puerto Rico at Mayagüez is tax deductible to company contributions.
5. With us your company will be promoted even further. Team RUMarino has already grabbed the attention from multiple media outlets in Puerto Rico, for example, appearing in the front page of the local newspaper such as "ÍNDICE" and WAPA Televisions with Ada Monzón.

Sponsorship Tiers

List of Benefits	Bronze (\$50- 1,499)	Silver (\$1,500- \$2,499)	Gold (\$2,500- \$4,999)	Platinum (\$5,000+)
Company's logo will be on the AUV and on the team's shirt.		✓	✓	✓
Access to our student members resumes.	✓	✓	✓	✓
Framed picture at the end of the school year.			✓	✓
Access upon request to facilities in our campuses for meetings and events.				✓
Company's name on promotional displays and websites.	✓	✓	✓	✓
Company has the opportunity to drive the AUV.				✓

Other quantities of donations are accepted. List of benefits to accompany those are developed upon receipt.



Payment Methods

We appreciate all your support and sponsorship. The Payments method the Team accepts are the ones mentioned below. If any doubts, do not hesitate in contacting us.

By Check

Make check payable to:

University of Puerto Rico - Mayaguez. Memo:
Rumarino Project - ECE Department

Send by Mail

Department of Electrical and Computer Engineering
University of Puerto Rico at Mayaguez,
Call Box 9000, Mayaguez, PR 00681



Sponsors

LOCKHEED MARTIN



Platinum (+\$5,000)



Primary Sponsor



Gold (\$2,500-\$4,999)



Silver (\$1,500-\$2,499)



Bronze (\$50-\$1,499)

Other companies that have sponsored us:



Insurance • Finance • Investments™



L3HARRIS™
FAST. FORWARD.



Contact Us

Faculty Advisor

Raúl Torres

787-644-3869

raul_e.torres@upr.edu

RUMarino Captain

Ordep E. Agustin

787-648-3193

ordep.agustin@upr.edu

RUMarino Email

rumarino.uprm@gmail.com

RUMarino Co-Captain

Kevin Y. Díaz Vélez

787-451-8457

kevin.diaz25@upr.edu



rumarino.org



rumarino_hydrus



RUMarino



RUMarino_pr

Thank you for your time and support!





We own the Depths